

## MECHANICAL INSTALLATION (TXISORAIL-HART)

The TxIsoRail-HART is meant for DIN rail mounting. Its dimensions are drawn in Figure 05 below.

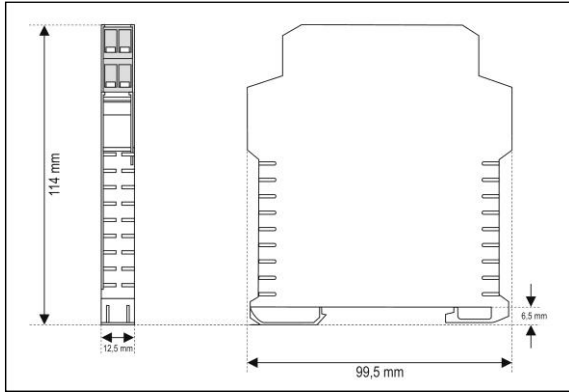

Figure 05 – Transmitter dimensions TxIsoRail-HART

## ELECTRICAL INSTALLATION (TXISORAIL-HART)

The Figure 06 shows the electrical connections required. The TxIsoRail-HART wiring for thermocouple, RTD, resistance and voltage are done according to the figure below.

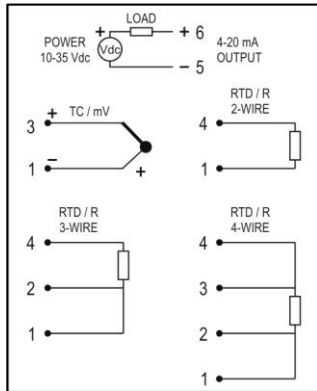

Figure 06 – TxIsoRail-HART transmitter electrical connections

**LOAD** represents the 4-20 mA current measuring device (indicator, controller, register, etc.).

### Recommendations for Installation

- Input signal conductors should run away from power and contactor wires, if possible, in grounded conduits.
- The instruments must be powered by a suitable network for instrumentation.
- System failure should always be taken into account when designing a system to avoid irreversible damage to equipment or people.
- Installing RC filters (47  $\Omega$  and 100 nF, in series) is strongly recommended at contactor coils or any other inductors.

## SPECIFICATIONS

**Sensor input:** Configurable. The supported sensors are listed Table 01, along with their corresponding ranges.

**Thermocouples:** Types B, E, J, K, N, R, S and T to IEC 60584  
Impedance  $\gg 1 M\Omega$

**Pt100:** Excitation 0.35 mA  $\alpha = 0.00385$ , according to IEC 60751

**Voltage:** 0 to 50 mVdc  
Impedance  $\gg 1 M\Omega$

SENSOR TYPE	MEASUREMENT RANGE	MINIMUM MEASUREMENT SPAN:
Thermocouple B	0 to 1820 °C	500 °C
Thermocouple E	-270 to 1000 °C	50 °C
Thermocouple J	-210 to 1200 °C	50 °C
Thermocouple K	-270 to 1372 °C	50 °C
Thermocouple N	-270 to 1300 °C	50 °C
Thermocouple R	-50 to 1768 °C	500 °C
Thermocouple S	-50 to 1768 °C	500 °C
Thermocouple T	-270 to 400 °C	50 °C
Pt100	-200 to 850 °C	20 °C
Pt500	-200 to 250 °C	20 °C
Pt1000	-200 to 250 °C	40 °C
Cu50	-50 to 150 °C	40 °C
Cu100	-50 to 150 °C	40 °C
* Ni100	-60 to 180 °C	50 °C
* Ni500	-60 to 180 °C	20 °C
* Ni1000	-60 to 150 °C	20 °C
Resistance	0 to 400 Ohms	20 Ohms
Resistance	0 to 2000 Ohms	20 Ohms
Voltage	-10 to 75 mV	20 mV
Voltage	-100 to 100 mV	20 mV
Voltage	-100 to 500 mV	20 mV
Voltage	-100 to 2000 mV	20 mV

\*  $\alpha = 5000$  ppm/K or 6180 ppm/K

Table 01 – Transmitter sensor list

**Output:** 4-20 mA, 2-wire, loop powered;

**Output Resolution:** 0.3  $\mu$ A (12 bits);

**Total Accuracy:** Maximum error 0.3 % of the maximum range for thermocouples; 0.2 % of the maximum range for Pt100;

**Power Supply:** 10.5 to 35 Vdc (voltage across the transmitter);

**Maximum Load (RL):**  $RL$  (max. in Ohms) =  $(Vdc - 10.5) / 0.022 A [\Omega]$ ;  
**Where:** Vdc= Power supply in Volts;

**Operating Temperature:** -40 to 85 °C;

**Humidity:** 20 to 90 % HR;

**Electromagnetic Compatibility:** EN61000-4-2, EN61000-4-3, EN61000-4-4, EN61000-4-6;

**Internal protection against polarity inversion in the loop voltage.**

**Cold junction compensation for thermocouples. Galvanic isolation.**

**Recommended wire gauge:** 0.14 a 1.5 mm<sup>2</sup>. Torque: 0.8 Nm.

# TxIsoPack-HART and TxIsoRail-HART

## OPERATING MANUAL



**NOVUS**  
WWW.NOVUSAUTOMATION.COM

Man 5001552

## SAFETY INFORMATION

Any control system design should take into account that any part of the system has the potential to fail. This product is not a protection or safety device and its alarms are not intended to protect against product failures. Independent safety devices should be always provided if personnel or property are at risk.

Product performance and specifications may be affected by its environment and installation. It's user's responsibility to assure proper grounding, shielding, cable routing and electrical noise filtering, in accordance with local regulations, EMC standards and good installation practices.

## SUPPORT AND MAINTENANCE

This product contains no serviceable parts inside. Contact our local distributor in case you need authorized service. For troubleshooting, visit our FAQ at [www.novusautomation.com](http://www.novusautomation.com).

## LIMITED WARRANTY AND LIMITATION OF LIABILITY

NOVUS warrants to the original purchaser that this product is free from defects in material and workmanship under normal use and service within one (1) year from the date of shipment from factory or from its official sales channel to the original purchaser.

NOVUS liability under this warranty shall not in any case exceed the cost of correcting defects in the product or of supplying replacement product as herein provided and upon the expiration of the warranty period all such liability shall terminate.

For complete information on warranty and liability limitations, check appropriate section in our web site: [www.novusautomation.com](http://www.novusautomation.com).

## INTRODUCTION

The temperature transmitters **TxIsoPack-HART** (head mount) and **TxIsoRail-HART** (DIN rail mount) are programmable devices that can be configured to work in a variety of industrial processes. The input sensor can be configured to accept RTDs, thermocouples, resistance and mV. They convert the sensor signal into a 4-20 mA output proportional to the measured value.

These transmitters offer digital communication by means of the HART protocol, through which the transmitter configuration and input monitoring can be accessed. In this protocol, the digital communication is superimposed to the current loop.

The input and output in the **TxIsoPack-HART** and the **TxIsoRail-HART** are electrically isolated, enhancing their performance and electromagnetic immunity.

## CONFIGURATION

If the transmitter is already configured to the application, it can be installed immediately. However, if a change in the configuration is required, this can be accomplished with the **TxConfig** software and then sent to the transmitter via the **TxConfig-HART Interface** connected to the PC USB port.

The **TxConfig-HART Interface** and software **TxConfig** consists of the **Transmitter Configuration Kit** which can be ordered from the manufacturer of its authorized representatives. The latest release of this software can be downloaded from our web site. To installing, run the **Tx\_setup.exe** file and follow the instructions.

The interface connects the transmitter to the computer, as shown in **Figures 01** and **02**:

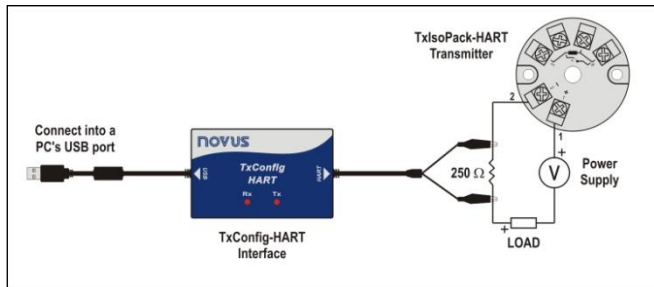

Figure 01 – TxConfig-HART interface connection to the TxIsoPack-HART

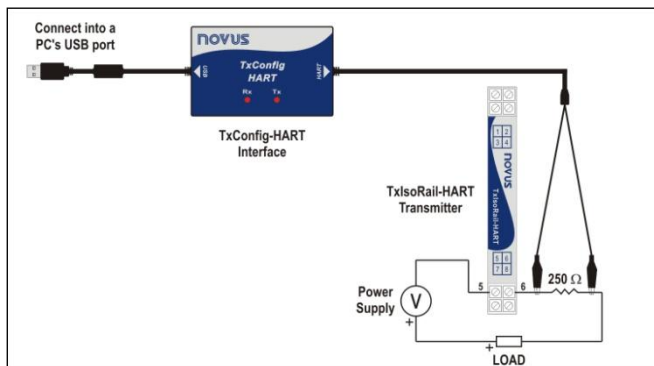

Figure 02 - TxConfig-HART interface connection to the TxIsoRail-HART

After the connections are made, the user must run the **TxConfig** software and, if necessary, use the *Help* topic to configure the transmitter.

The fields in this software have the following purposes:

- Sensor:** Sets the sensor to be used. See **Table 01**.
- Measure:** Sets the transmitter measurement range (minimum and maximum values).  
When the Lower Limit is set with a value higher than the Upper Limit value, the output current operates between 20 and 4 mA  
The values chosen cannot exceed the **Sensor Range** shown in this same field, and also may not establish a range with width (span) smaller than the **Minimum Range** indicated later in this same field. See **Table 1** of this manual.
- Filtering:** Filters the measurements made by the transmitter eliminating interferences from the electrical system that feeds the process.
- Failure:** Establishes the behavior of the output when problems are present by the sensor. When **Minimum** is selected, the output current shifts to < 4 mA (*down-scale*), typically used in refrigeration. When **Maximum**, is selected > 20 mA (*up-scale*), typically used for heating.
- Zero Correction:** Corrects minor errors presented by the transmitter, for example, when the sensor is changed. See item *Operation* in this manual.
- Transmitter Information:** In this field, there are data that identify the transmitter. This information must be informed in any consultation with the manufacturer.
- Send Configuration:** When selected, this allows one to send the configuration to the transmitter connected.
- Read Configuration:** When selected, this allows one to read the configuration on the transmitter connected.

**Note:** If on the purchase order the user does not define a specific configuration, the following configuration will be set:

- Pt100 sensor, range 0 to 100 °C, 0 °C zero correction.
- Filter to 2 µA and maximum output for sensor failures.

## OPERATION

The transmitter is perfectly factory calibrated with standardized sensors, not requiring any adjustment by the user.

Fine corrections can be accomplished through the **TxConfig** software (in units of temperature).

The user may choose the sensor and the span that best fits its application. The sensor span must lie within the range specified for the selected sensor.

It is important to note that the accuracy of the transmitter refers to the maximum range of the sensor used, regardless of the actual span. Example:

- The sensor Pt100 has a max. range of -200 to 850 °C and total accuracy of 0.2 %.
- Thus, we can have an absolute error up to 1.7 °C (0.2 % of 1050 °C).
- This error is the same no matter if total span is used (-200 to 850 °C) or a narrower user-defined span is used, like 0 to 100 °C

## MECHANICAL INSTALLATION (TXISOPACK-HART)

The **TxIsoPack-HART** is designed for head mounting.

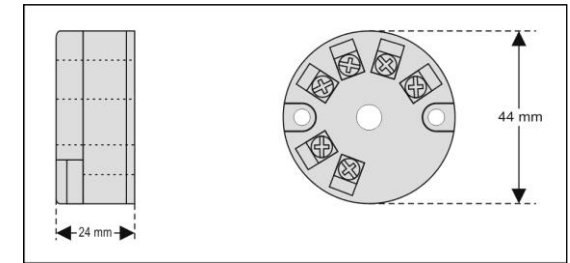

Figure 03 –TxIsoPack-HART dimensions

## ELECTRICAL INSTALLATION (TXISOPACK-HART)

Refer to the **Figure 04** below for the transmitter required connections (loop excitation and sensor wiring: thermocouple, RTDs, resistance or mV).

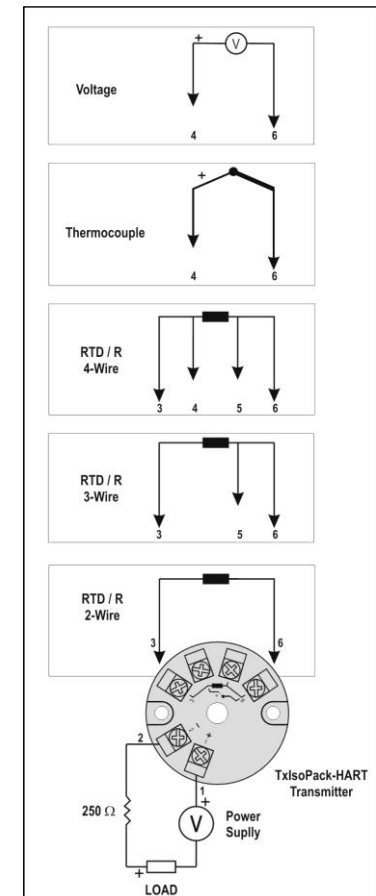

Figure 04 – TxIsoPack-HART transmitter electrical connections